

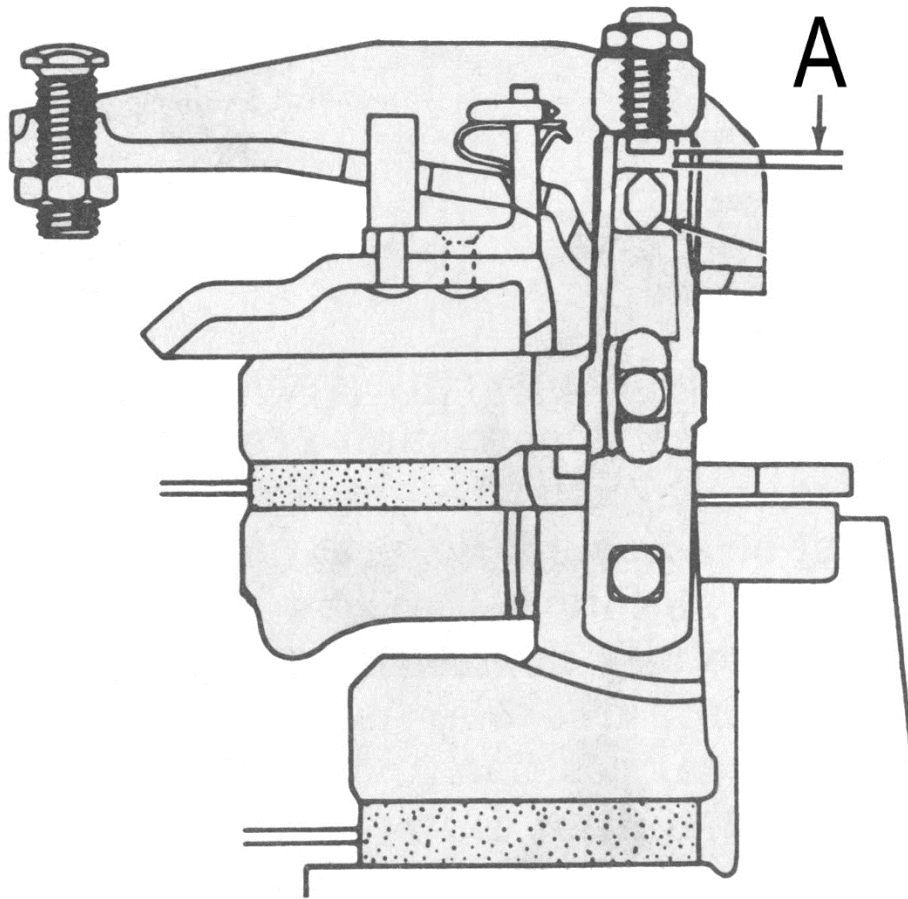

FD802AA KIT [11" Dual Stage Clutch Kit, w/Bearings & Alignment Tool - Reman]

Instruction Guide



Flywheel measurement from clutch mounting surface to disc friction surface: 1.750"
Verify PTO Gap (A) using the smooth shank of a 1/16" drill bit as a gauge.

